

NO.	DATE	REVISION	REVISER	VERSION

NOTES UNLESS OTHERWISE SPECIFIED

- 1. MATERIAL OF HOUSING: PC.
- 2. ELECTRICAL TEST: Dielectric withstanding volts: 500AC
Insulation Resistance: 500mega ohms
Termination Resistance: 35milliohms max

3. PART NO. MATRIX:

PJM3 xxx xx-xxxx-x

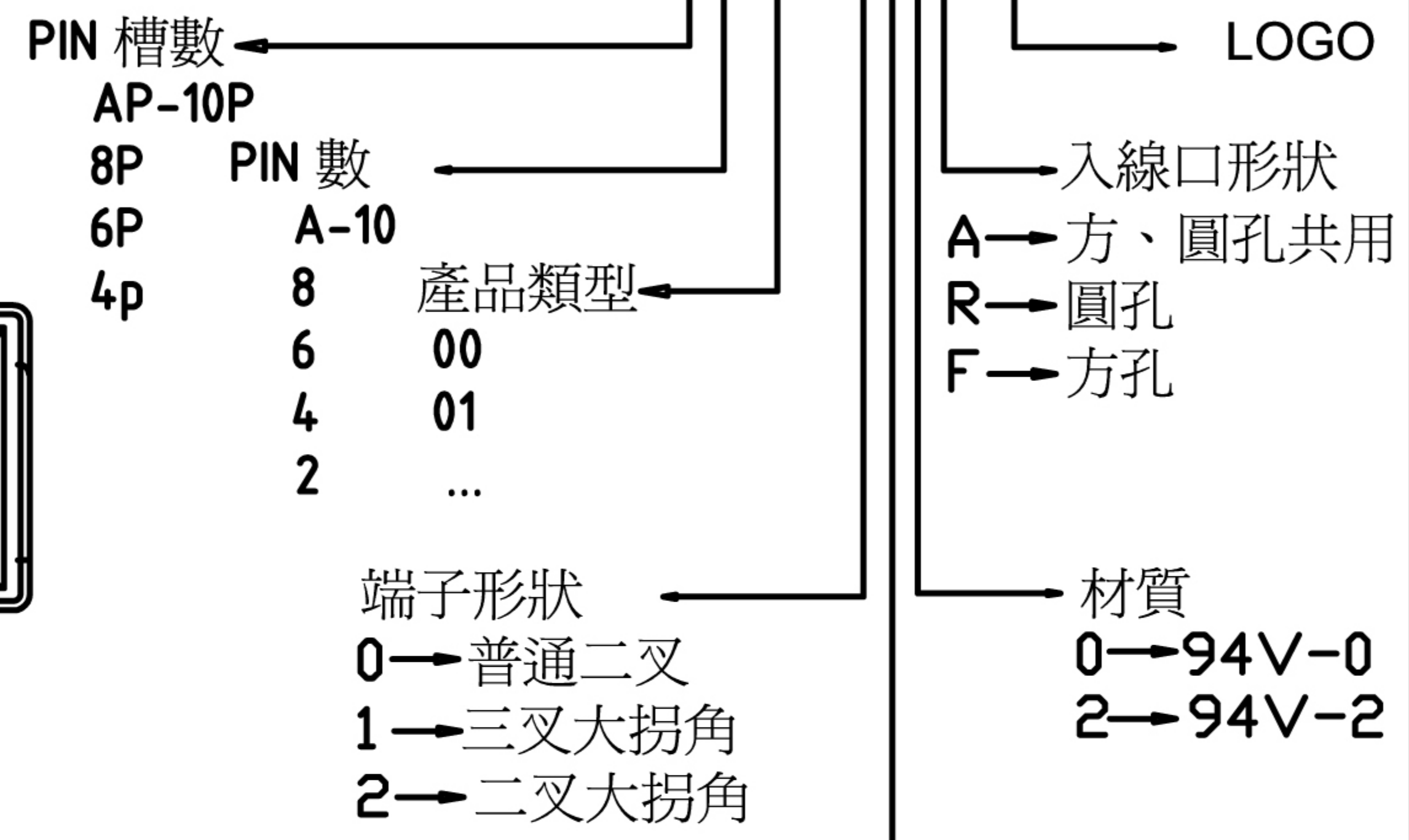

- 電鍍 GOLD
- 1 → CONTACT ARER 10U GOLD PLATED
 - 2 → CONTACT ARER 20U GOLD PLATED
 - 3 → CONTACT ARER 30U GOLD PLATED
 - 4 → CONTACT ARER 40U GOLD PLATED
 - 5 → CONTACT ARER 50U GOLD PLATED
 - 6 → CONTACT ARER 3U GOLD PLATED
 - 7 → CONTACT ARER 6U GOLD PLATED
 - 8 → CONTACT ARER 1U GOLD PLATED
 - 9 → CONTACT ARER 15U GOLD PLATED

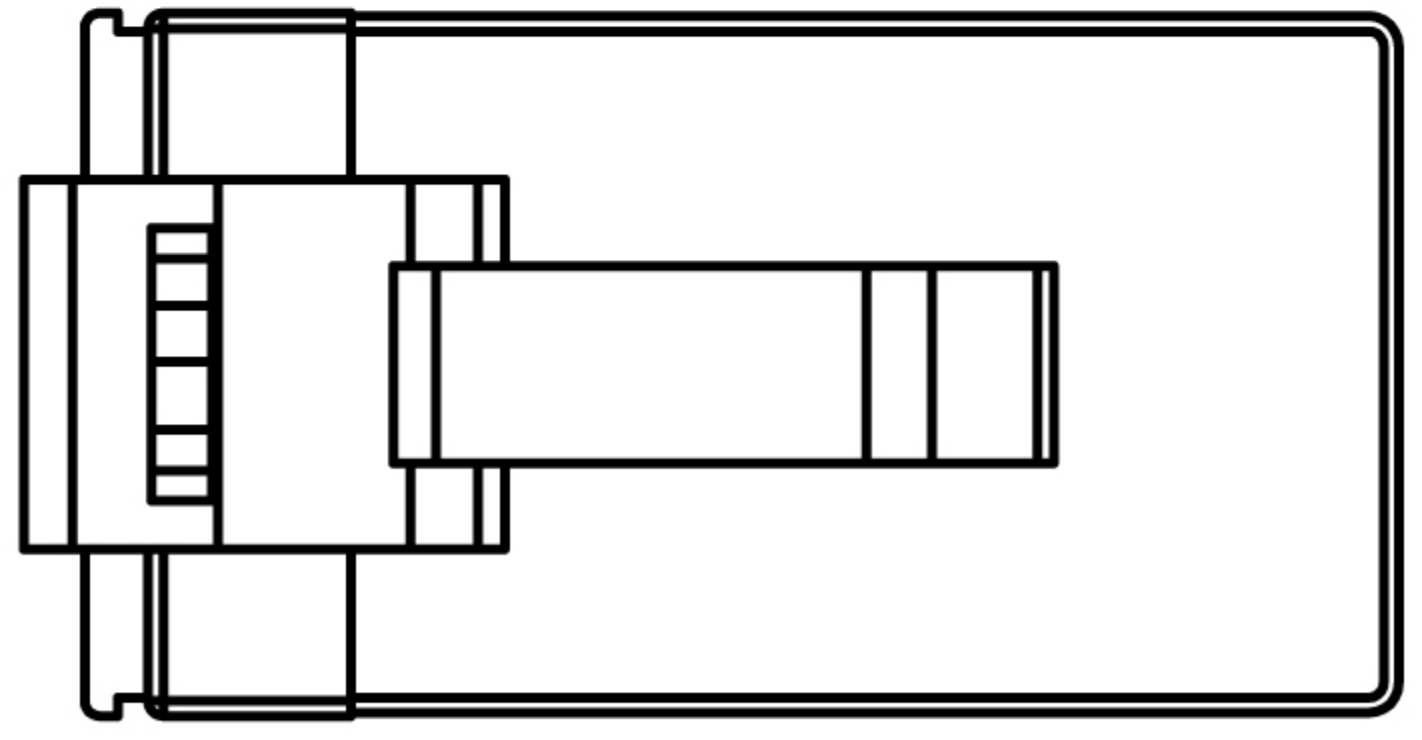
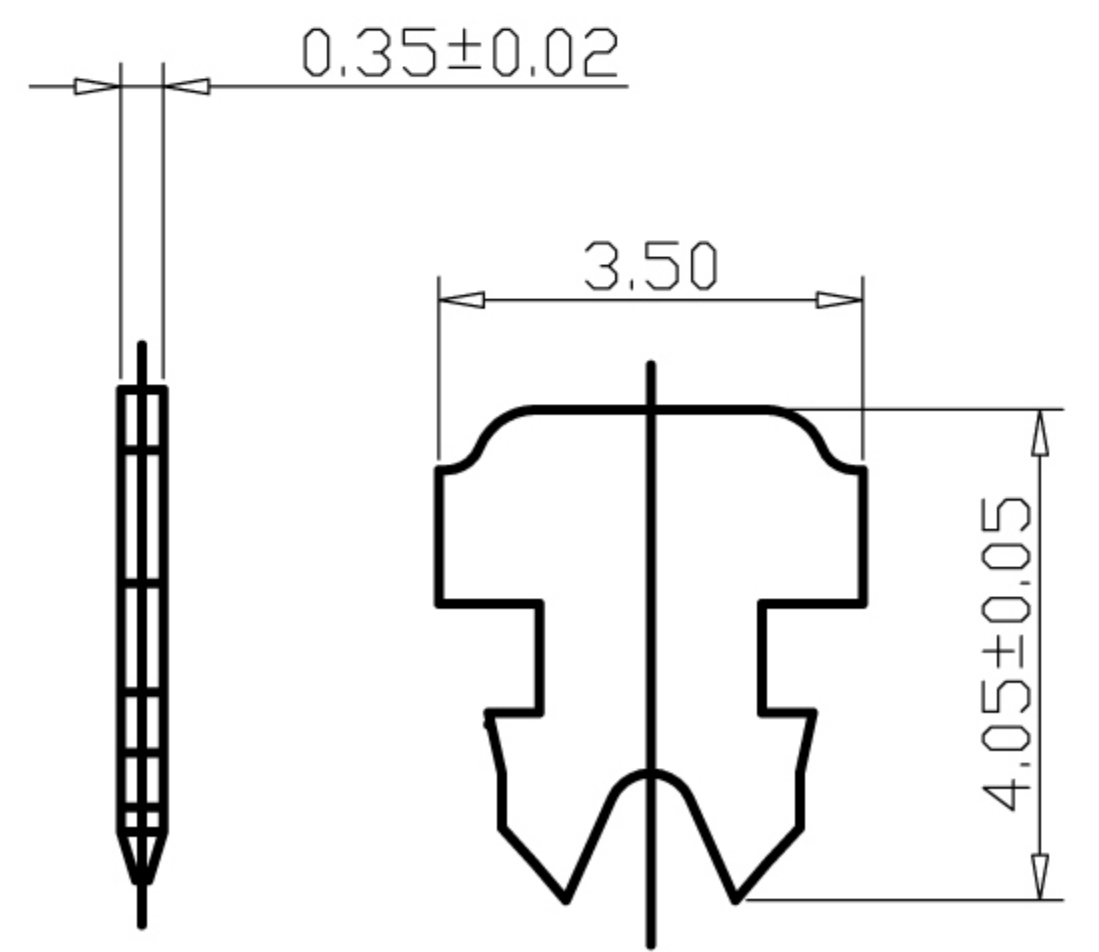
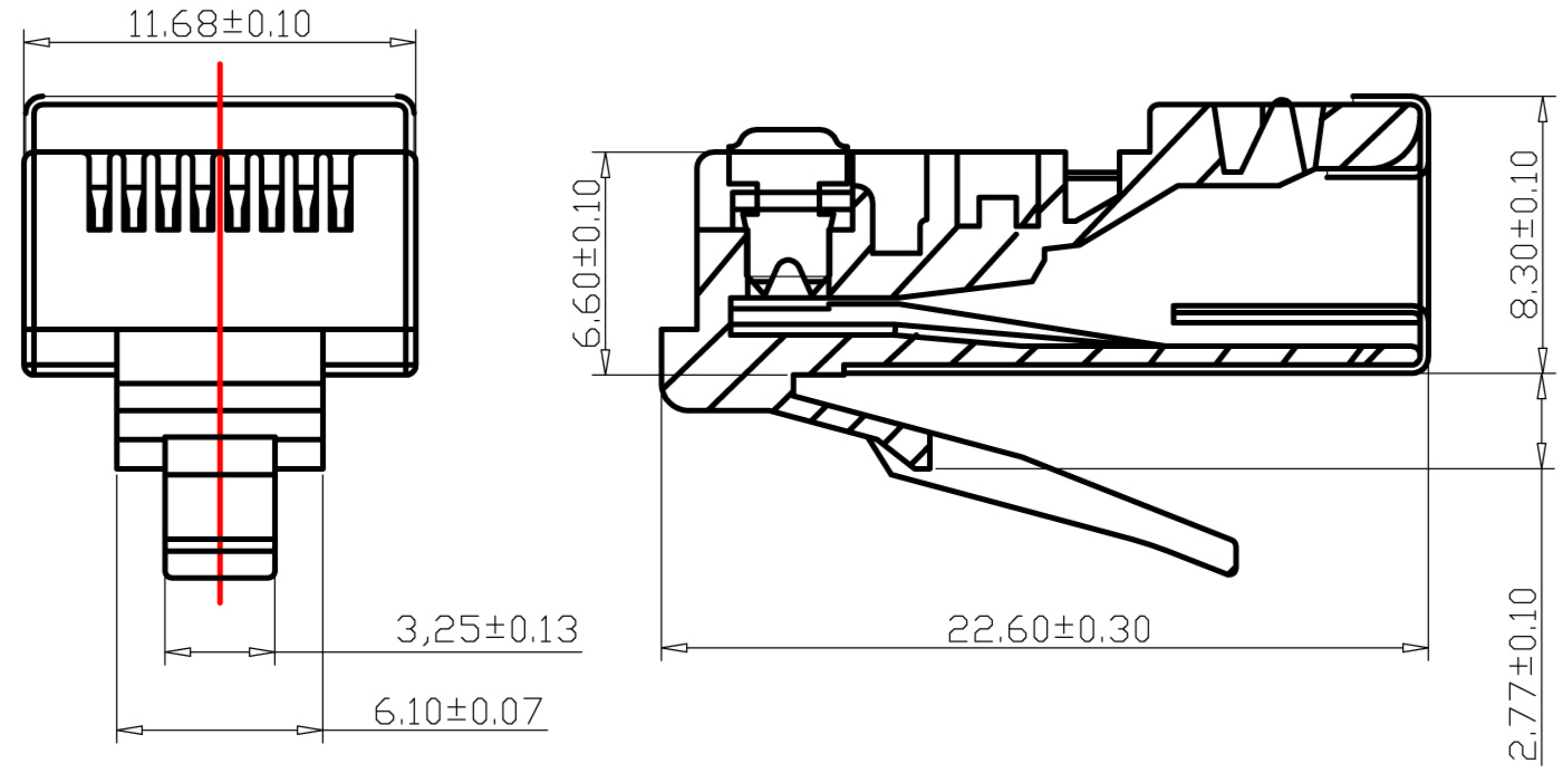
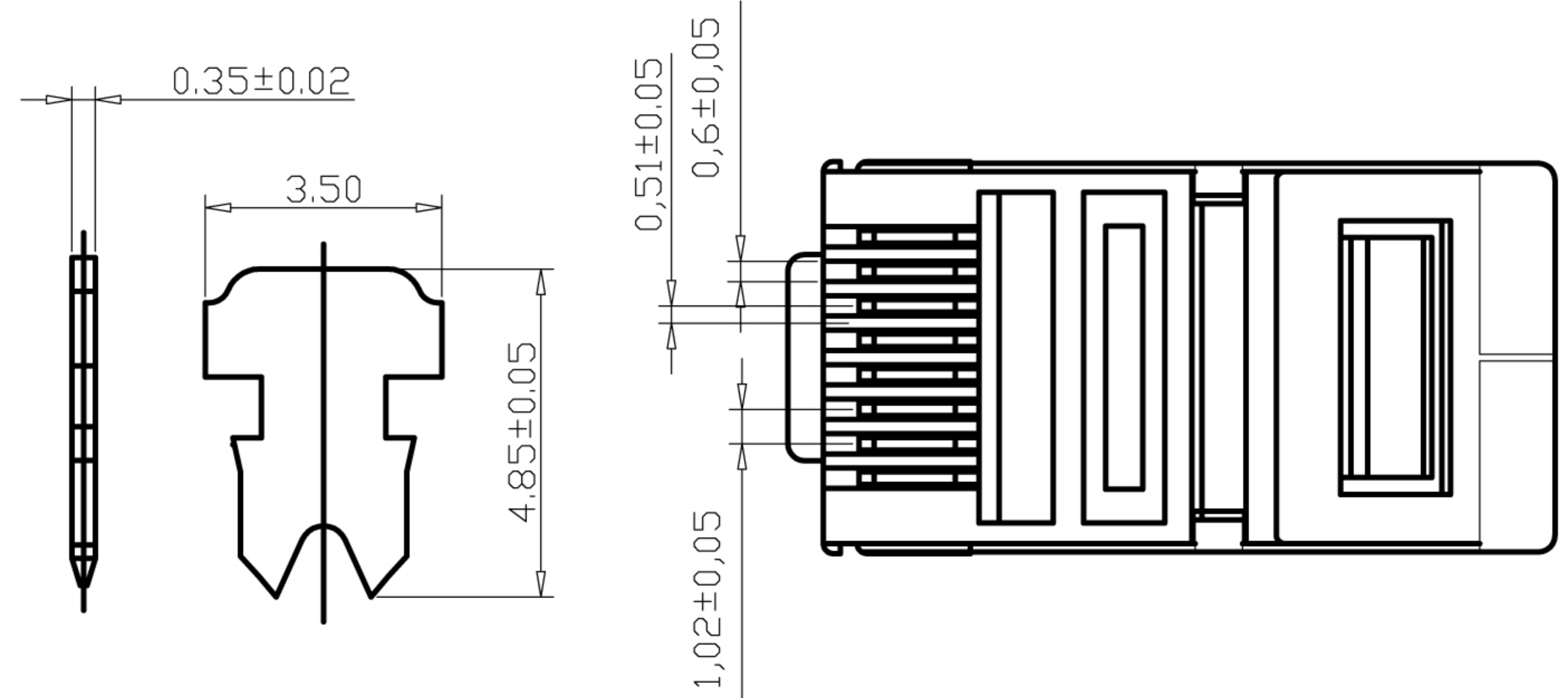

APPROVED	J.S.Zhong	PC	8P8C 雙線孔 PLUG(雙線)	m/m	SHENZHEN HSD CABLE CO., LTD	
CHECKED		MATERIAL	NAME	UNIT	±0.1	
DRAWN		ICP-0042-A0	PJM38P817-0XXR-0	WEIGHT	THIRD ANGLE PROJECTION	GENERAL TOLERANCE
DESIGNED	Y.Cheng	DWG NO.	PART NO.	SCALE	SURFACE ROUGHNESS	VERSION
		透明	射出成型	1:1		A/O
		COLOR	MANUFACTURE			